

TOTO

Auto-cleaning Urinal (USWN900 Series • USWN902 Series)

Install the product properly according to these Work Instructions, to ensure that its functions perform sufficiently. After installation, provide the customer with a clear explanation of how to use the product.

Safety Precautions (be sure to read to ensure safety)

Read these "Safety Precautions" prior to construction, and install the product correctly. These Instructions include a variety of safety indications. These are provided so that the product can be used safely, to prevent harm to customers or others, and to prevent damage to property. These indications and their meanings are as follows:

Indication	Meaning
WARNING	Ignoring the text accompanying this indication and handling the product incorrectly could result in death or serious injury.
CAUTION	Ignoring the text accompanying this indication and handling the product incorrectly could result in serious injury or property damage.

* "Property damage" refers to damage extending to the home/household property and domestic animals/pets. Types of safety precautions that must be followed are classified using the two following symbols for explanatory purposes.

	indicates a prohibited use of the product. The symbol to the left indicates that "use is prohibited in bathtubs and shower stalls."		indicates a required step in the use of this product. The symbol to the left indicates the action is "REQUIRED."
--	--	--	---

WARNING

Do not install in locations of high humidity such as bathrooms. Doing so may cause a malfunction or current leak.

People other than repair technicians should never disassemble, repair, or alter the product. Doing so may cause a malfunction, electric shock, or injury.

CAUTION

REQUIRED

Always carry out construction work with at least two people. Otherwise, the installer may injure his or her lower back, or drop the porcelain and damage it.

After construction, be sure to give the product a test run and check that there are no water leaks in any part. Not installing the product properly may cause water leaks that could result in flooding damage to property, such as household belongings.

Included Parts

Refer to the following and confirm that no parts are missing.

Upper lid		Drain cover	
* e water+ type with sponge			
Urinal	Water supply fixture	Others	
	Shutoff valve (1)	DC Dry Battery only	Hand this over to the customer
	Quick fastener (1)	Battery box (1)	
		Alkaline batteries(2) *For Malaysian Type, please procure locally.	Installation Manual (1; this document)
			Instruction Manual (1)
Draining Flange			

Precautions prior to Installation

WARNING

Do not install in locations of high humidity such as bathrooms. Doing so may cause a malfunction or current leak.

REQUIRED

Be sure to install an overcurrent breaker and earth leakage circuit breaker in order to prevent danger. Electric wire: Use a 600V plastic shielded electric wire or cable (A ϕ 1.6 mm or ϕ 2.0 mm single wire, or 2.0 mm stranded wire). Insulate and waterproof the power wire connector. Do not insert the power wire connector inside the device. Doing so may cause electric shock, a current leak, or a fire.

- Thoroughly discuss the relevant procedures before performing water and electrical work.
- The power wire is to be provided on-site. (AC type only)
- A grounding wire is not needed, so use a two-core power wire. (AC type only)
- Water supply pressure ranges from 0.07 MPa (9 L/min [dynamic]) at minimum to 0.75 MPa at maximum. Use the product within this pressure range.
- Be especially careful not to damage the surface of the sensor.
- This product is an electrical appliance. Be careful not to spray water on it. The exposure angle and detection distance of the sensor are as shown in the diagram. When installing a handrail or the like in front of the urinal, do so in a way that does not obstruct the detection areas (both the stable detection area and unstable detection area) of the photoelectric sensor. Urinal sensors may mal-operate affected by reflective objects such as mirrors and stainless steel. Cases also happen when ground reflection caused by these items installed vertically even beyond 3m.
- The product may not function in environments exposed to strong sunlight.
- Inverters or other devices that use infrared light could cause malfunctions.
- A water supply inspection has been conducted prior to packaging. There may be some water remaining inside the product, but this is normal.

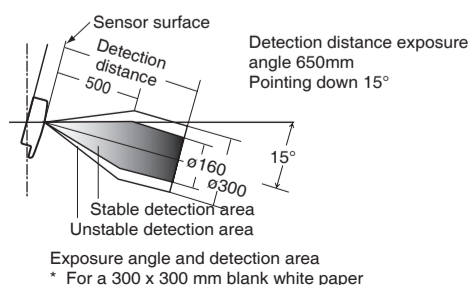

Parts Names

USWN900 Series • USWN902 Series

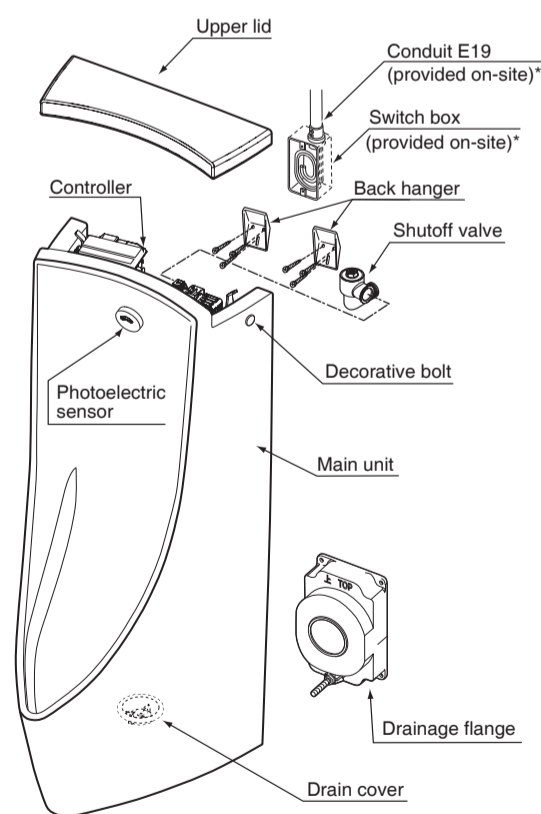

* is for AC type only

As-fitted Drawing

USWN900 Series

(Unit: mm)

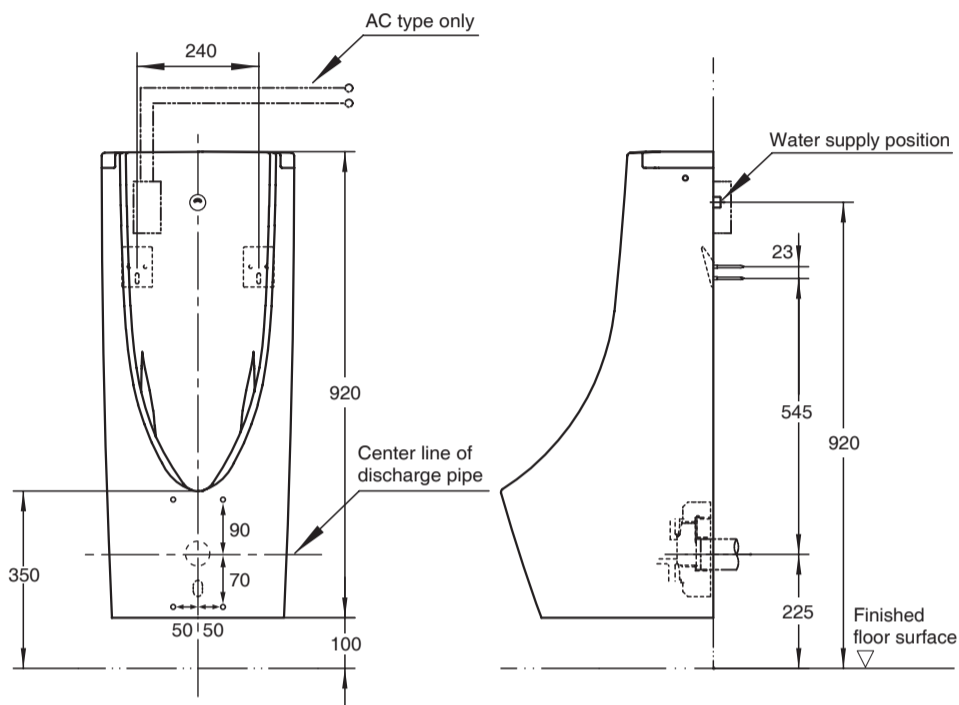
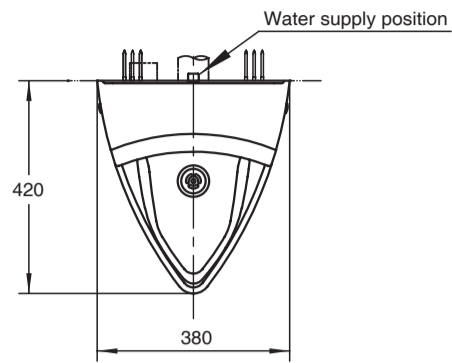

USWN902 Series

(Unit: mm)

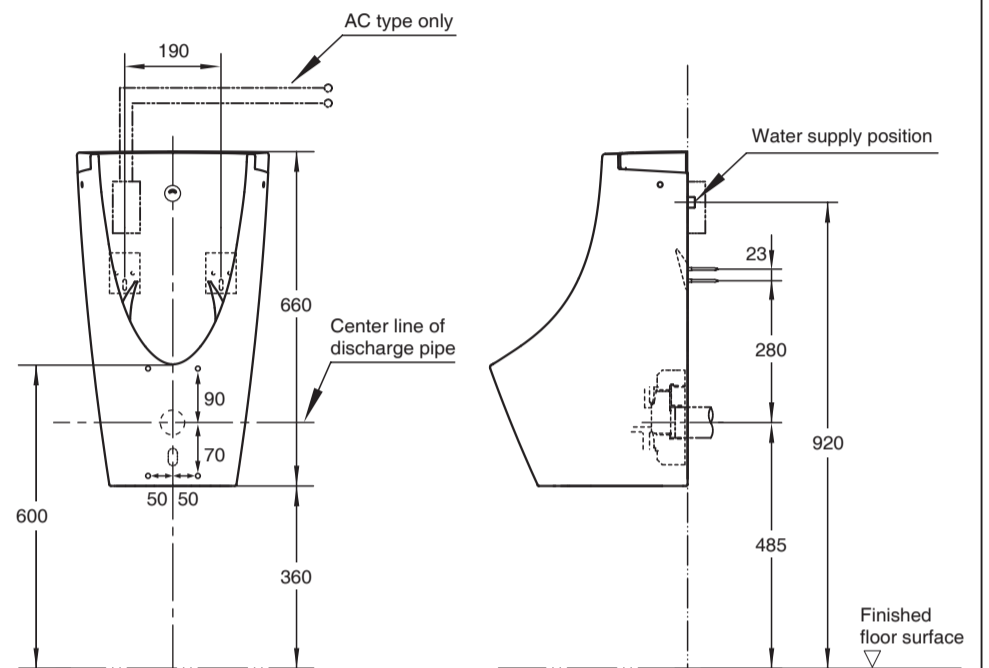
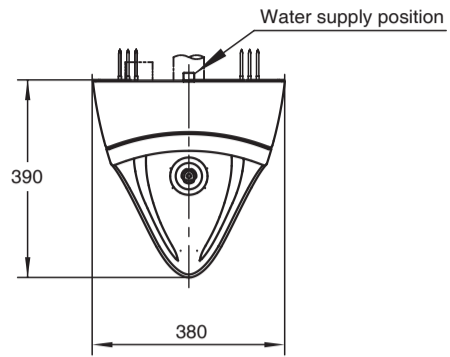

Construction Procedure

220-240V AC electrical work is required only for the AC type. Be sure to perform construction steps ① through ③ prior to installing the urinal.

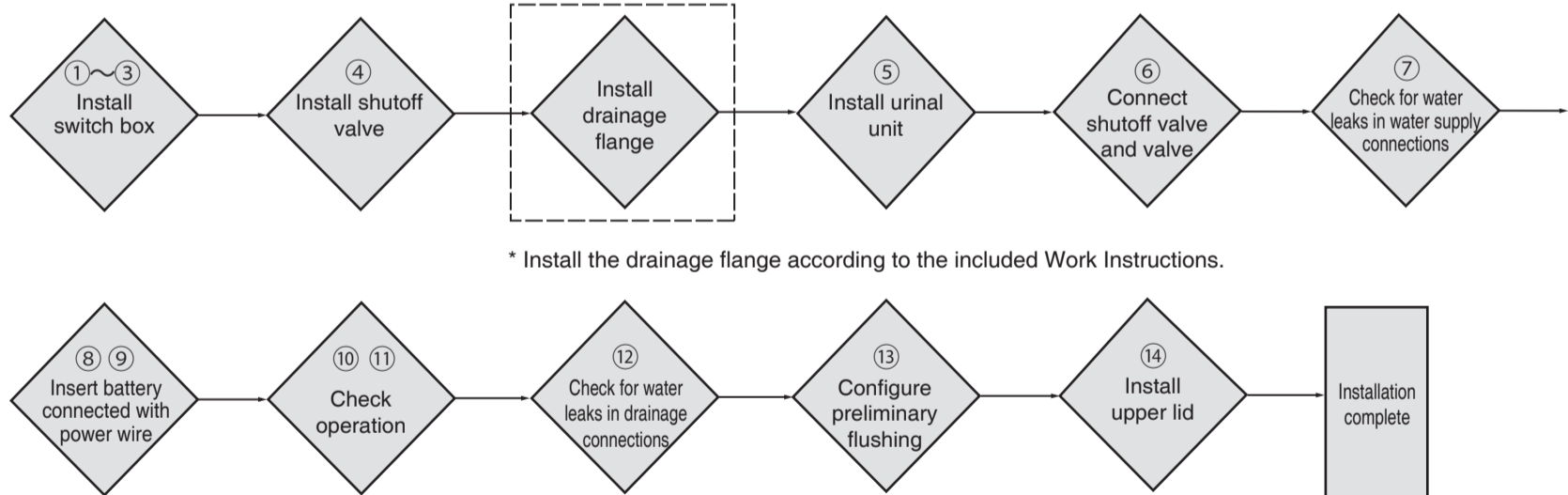

* Install the drainage flange according to the included Work Instructions.

Installation Method

① Mark the switch box installation position (for wet and dry construction)

Mark the center line of the installation position on the foundation wall.

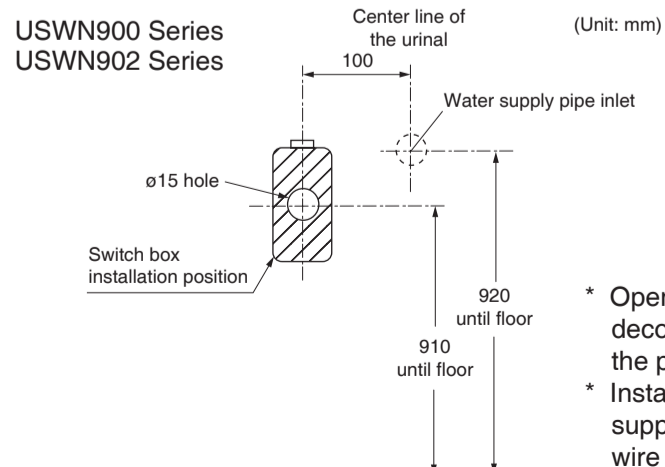

- * Open a $\phi 15$ hole in the decorative board, and pull the power wire inside.
- * Install so that the water supply pipe and power wire do not touch.

⚠ WARNING



The water supply pipe and power wire must not touch. Doing so may cause a malfunction or current leak.

② Pare the foundation wall down

Pare the foundation wall down according to the dimensions in the diagram.

USWN900 Series
USWN902 Series
910 until floor

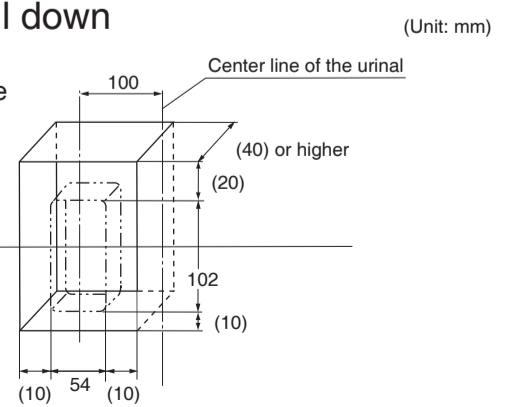

Continued on other side

3 Install the switch box and backfill the foundation wall

① Connect the power wire and switch box to the conduit connector, pass the power wire through the conduit, and pull it into the switch box.

- * Use a switch box for a single device (no cover).
- * A grounding wire is not needed, so use a two-core power wire.
- * Use a screwless conduit (nominal designation, provided on-site).
- * Leaving around 40 cm of slack outside the box, wind the power wire inside the box.

② Fill the area around the switch box with mortar.

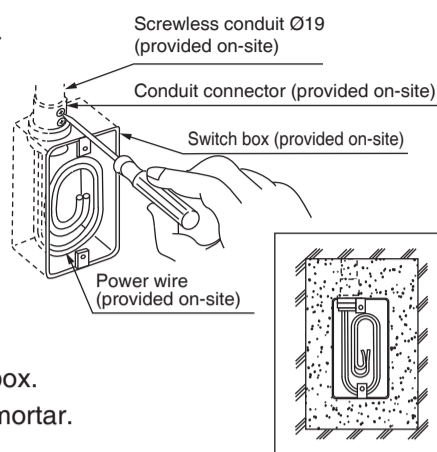

4 Install the shutoff valve

CAUTION Be sure to supply water through the water supply pipe to flush out any dirt prior to installation.

Wrap seal material around the connector and screw the shutoff valve in the direction of the arrow.

- * Work the shutoff valve so that it is within the construction error tolerance level.
- * Install the shutoff valve parallel to the wall. There may be cases where parts touch the porcelain and cannot be installed.

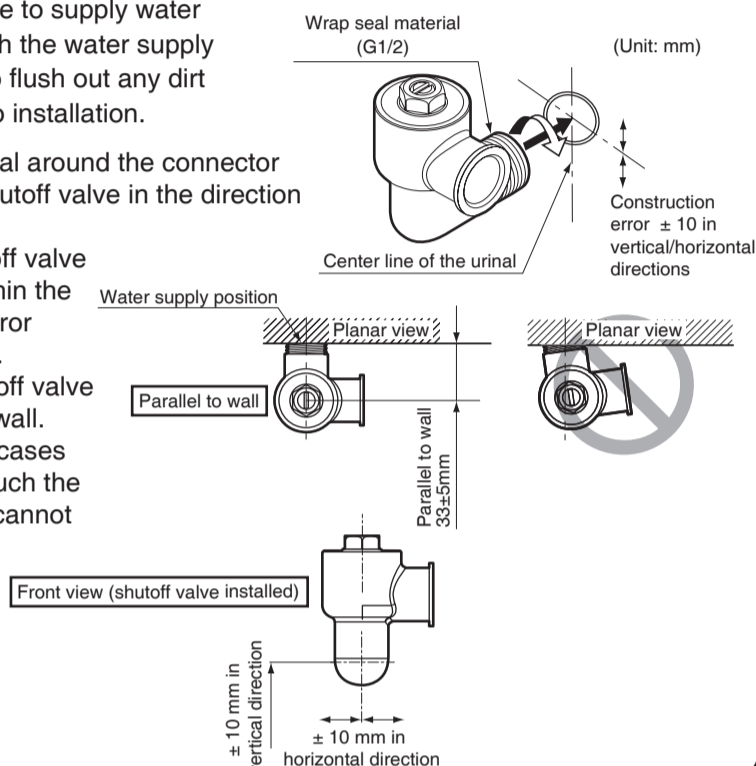

5 Install the urinal unit

Install the back hanger to the location shown in the diagram.

	*1 (size)	*2 (size)	*3 (size)
USWN900 Series	120mm	545mm	225mm
USWN902 Series	95mm	280mm	485mm

Drill a pilot hole of around Ø3 at the marked installation hole position.

- * Drilling a pilot hole of around Ø3 will make it easier to work.

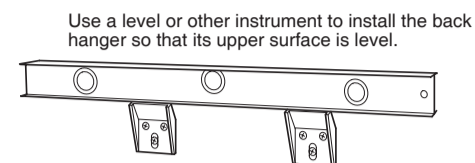

Do not immediately fix the back hanger with the three wood screws; instead, temporarily fix it with the elliptic holes only.

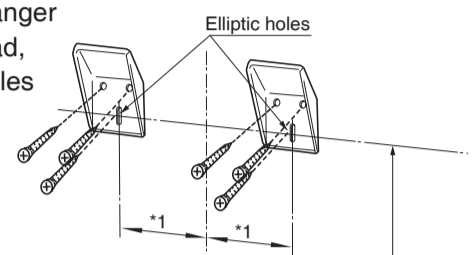

Attach the seal ring onto the urinal for a trial at first, hang the urinal from the back hanger, adjust it to the indicated position, then fix it in place. If the urinal does not reach the indicated height, loosen the back hanger's wooden screws, then place a metal plate between it and the wall to adjust it.

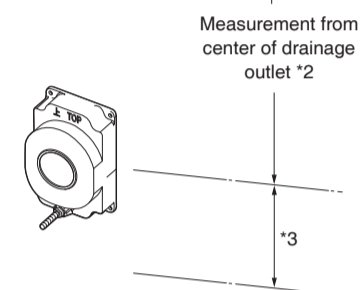

Key points

- Pull the power wire around 25 cm toward the shutoff valve, in order to make it easier to connect the power wire and terminal block.

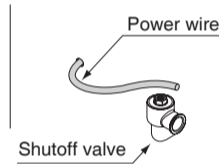

5 Install the urinal unit (continued)

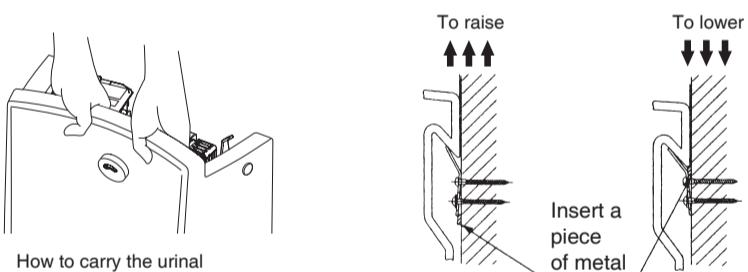

Clean the area around the urinal drainage outlet of dirt and water, then attach the seal ring to the urinal drainage outlet.

Align the centers of the urinal drainage outlet and drainage flange, then hang the urinal unit from the back hanger.

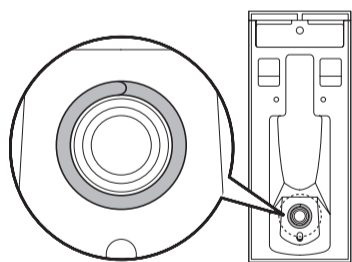

CAUTION

Prohibited Do not install the urinal unit from the drainage outlet side. Doing so could cause water leaks from the drainage flange that could result in flooding damage to property, such as household belongings.

Fix the flange bolt to the lower part of the urinal with the washer (large) and nut.

- * The washer (large) and nut are packaged with the drainage flange.

CAUTION Be careful not to tighten the nut too strongly and crack the urinal unit. Be careful that the shutoff valve does not strike the urinal unit.

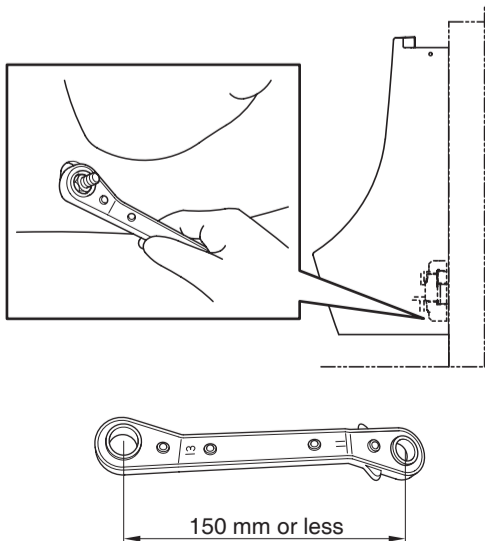

- * The hex size of the nut is 13 mm. A board ratchet wrench with a total length of 150 mm or less is recommended to tighten the nut.

6 Connect the shutoff valve and valve

CAUTION



REQUIRED Be careful that the valve's O-ring is not dirtied or damaged. If the O-ring is dirtied, damaged, or sticks out, it could cause water leaks that could result in flooding damage to property, such as household belongings.

Use the quick fastener to connect the shutoff valve and valve.

- * The quick fastener is inside the shutoff valve's box.

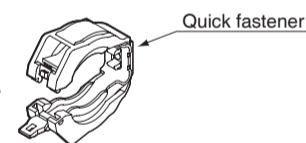

<Installation Method>

Remove the hygienic sheet on the valve's O-ring.

Insert the valve straight into the shutoff valve.

- * Align the recess on the shutoff valve's flange with the projection on the valve's flange, then insert.

Align the flanges on the shutoff valve and valve, then insert the quick fastener.

- * If the valve is not fully inserted, it will be impossible to install the quick fastener.

Confirm that the flange is fully inserted into the recess on the quick fastener, rotate it to the front and rear, then check the connection between the shutoff valve and valve.

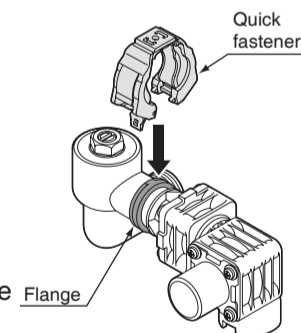

Rotate the quick fastener and check the connection.

CAUTION Refer to the Installation Manual attached to the urinal for information on how to install the quick fastener.

CAUTION



REQUIRED If the quick fastener does not rotate smoothly after connecting it, reconnect it. If the quick fastener is not connected properly, water leaks could result in flooding damage to property, such as household belongings. Install the quick fastener properly, then check visually or through other means.

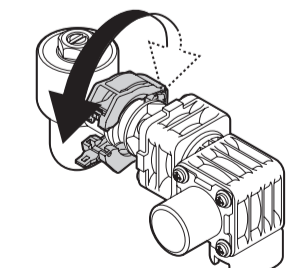

Make sure the quick fastener cover is locked, then fix it in place.

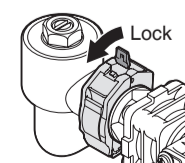

7 Check for water leaks in the water supply connections

After confirming that there are no pipe connection problems, supply water through the piping, and confirm that there are no water leaks in the connections between the piping and shutoff valve, and between the shutoff valve and valve.

8 Connect the power wire (AC type, e water+ type)

CAUTION

Confirm that no current is applied before connecting the power wire
Failure to do so may cause electrical shock.

The power supply terminal block and primary power supply must be connected by a qualified person only
Failure to do so may cause a malfunction or electric shock.



REQUIRED

When inserting the power wire (VVF) into the terminal block, insert the grounded side of the wire into the white line side, and the non-grounded side of the wire into the black line side
Failure to do so may cause fire.

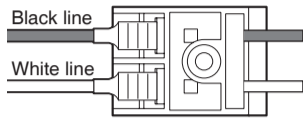

WARNING

When removing the power wire, always be sure to press the white part on the surface of the power supply terminal block with a flat-head screwdriver, then remove the wire.

Pulling the power wire out with unreasonable force may cause damage to the controller.

REQUIRED

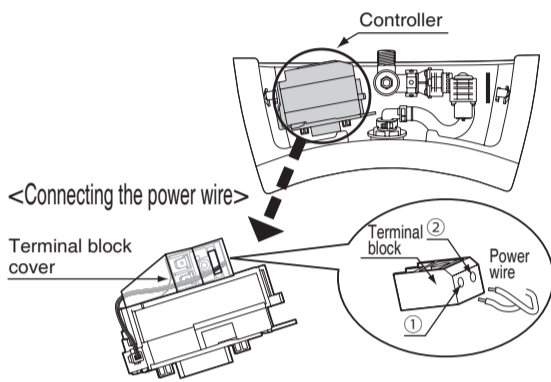

Key points

Run the electric wire so that it does not hang over the top of the shutoff valve.

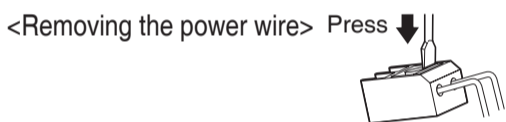
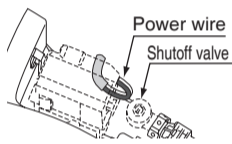

CAUTION If the waterproof cover is removed, cover the controller.

Take the power wire out of the switch box, pass it through the rear of the waterproof cover, and connect it to the two terminals (1 and 2).

* Cut the power wire if it is too long.

* Strip the gray covering on the power wire 25 to 30 mm from the end. This will make it easier to connect the power wire and terminal block.

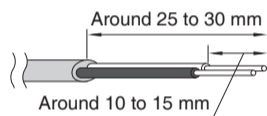

9 Insert battery (DC Dry Battery type only)

Remove the waterproof cover.

Insert the alkaline battery into the battery box, then connect the controller connector and battery box connector.

* For 10 minutes after connecting the battery box, the LED flashes during photoelectric sensor detection to enable the detection status to be confirmed. The lamp does not flash even when it detects something after this 10 minute period.

Install the waterproof cover.

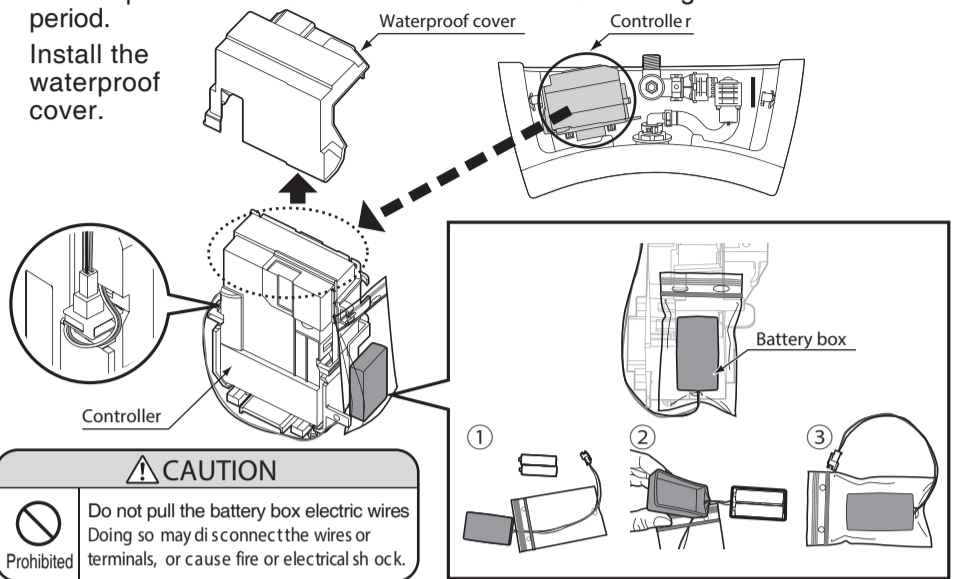

CAUTION

Do not pull the battery box electric wires
Doing so may disconnect the wires or terminals, or cause fire or electrical shock.



10 Adjust the photoelectric sensor detection range

The detection range is automatically adjusted when the power is turned on.

* The photoelectric sensor's automatic detection range adjustment function operates soon after power is activated. If the photoelectric sensor lamp continues to flash or stay lit¹ when the unit detects something other than a human, this means that the detection range is currently being adjusted. Be careful that the sensor is not triggered by a human before the lamp turns off.

* If a human is detected when the lamp is flashing or lit¹, it will take longer to adjust the detection range. Adjustment is complete when the lamp turns off.

*1: DC Dry Battery type flashes;
AC type stays lit



CAUTION Be sure to turn the power on with water being supplied.

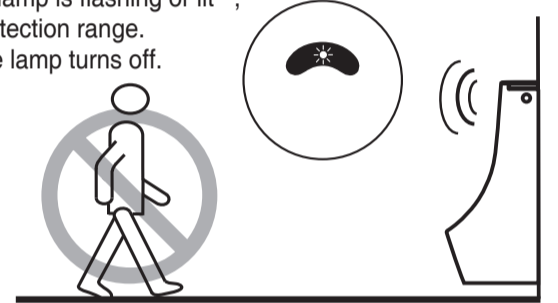

11 Confirm that the urinal flushes

Confirm that the photoelectric sensor's lamp turns off when no human is detected. Trigger the photoelectric sensor and confirm that the urinal flushes.

Please adjust the stop-valve flow if the water can't reach the front end of the urinal when flushing.

* AC type units will automatically flush the urinal immediately after electric current is applied. Confirm the above once automatic flushing is complete immediately after electric current is applied.



Sensor not flashing

Sensor detection

Flush

w/ button

* If the photoelectric sensor flashes when it has not detected a human, this means that the photoelectric sensor is automatically adjusting the detection range. Wait until the lamp stops flashing. (See "10 Adjust the photoelectric sensor detection range" for more details)

* If the urinal has a manual flush button, after confirming that the urinal flushes by photoelectric sensor detection, confirm that the urinal flushes when the button on the right side of the urinal is operated.

12 Check for water leaks in the drainage connections

After confirming that there are no pipe connection problems, supply water through the piping, and confirm that there are no water leaks in the connections between the piping and shutoff valve, and between the shutoff valve and valve.

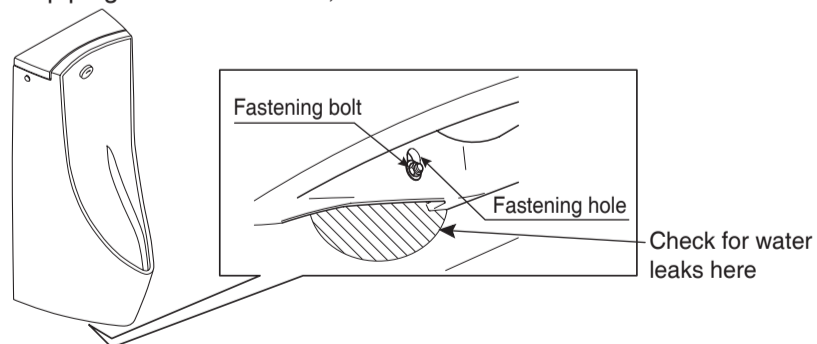

13 Configure preliminary flushing (switch as needed)

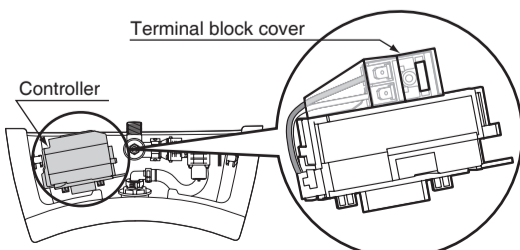

CAUTION

Do not remove the terminal block cover covering the terminal block
Touching the terminal block may cause electrical shock.

* The preliminary flushing switch is set to "OFF" by default.

13 Configure preliminary flushing (continued)

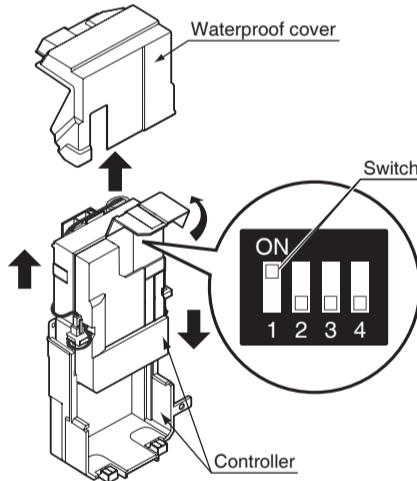

Remove the waterproof cover.

Slide the controller up.

Open the setting switch cover on the controller, and turn switch 1 ON. After setting the switch, return the waterproof cover, controller, and setting switch cover to their original positions.

* Switches 2 through 4 have no effect on the preliminary flushing setting. If switches 2 through 4 are mistakenly turned ON, be sure to turn them OFF.

14 Install the upper lid

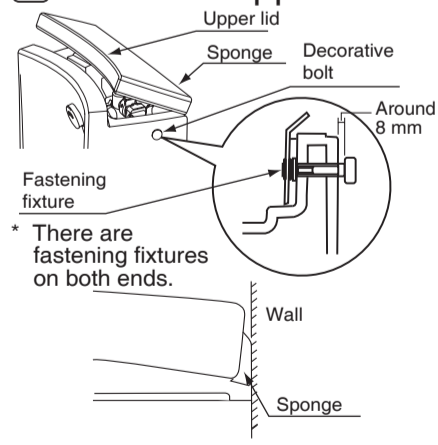

* There are fastening fixtures on both ends.

Hold the fastening fixture down from inside the urinal, then use a hex wrench (nominal designation 4) to loosen the decorative bolt. Bring the decorative bolt to the outside. (Reference: Gap of approximately 8 mm) While pressing the sponge attached to the rear surface of the upper lid against the wall, place the lid.

Use a hex wrench to turn the decorative bolt, then fasten the urinal unit and upper lid.

* Be careful not to tighten the decorative bolt too strongly and crack the urinal unit or upper lid.

* If there is a gap between the upper lid and urinal unit after fastening the upper lid, loosen the decorative bolt, then tighten both sides again equally until there is no gap.

* Install only the upper lid that came packaged with the unit. The upper lid and urinal unit are manufactured together as a single unit. Using an upper lid other than the one packaged with the unit could cause looseness.

* Use the numbers on the number stickers attached to the storage side surface of the urinal unit and the underside of the upper lid to check the combination.

If the fastening fixture is removed, refer to the diagram to the left for assembly.

