

TOTO

Wall mounted toilet bowl / Wandmontierte Toilettenbecken / WC suspendu / Water a parete / 벽걸이 양변기 / 壁掛式馬桶

EN

Perform the installation work properly according to this Installation Guide so that the product can function well. After installation, fully explain how to use it to your customer.

For Australia, installation to be in accordance with AS/NZS 3500 series of Standards and /or local regulations.



Cautions and warnings (Always observe these warnings.)

Before installation, read these "Cautions and warnings" carefully and attach the equipment correctly. This manual uses various indications to guide safe installation of the product and to prevent injury to customers or other people and damage to property. This product should be installed by a professional. The indications and their meanings are as follows.

Symbol example	Meaning of symbol
 CAUTION	This indicates that misoperation could result in injury or physical damage.

The following symbols are used to classify and explain instructions that must be followed.

	The  symbol indicates something that is prohibited.		The  symbol indicates something that must be done.
--	---	---	---

 CAUTION	
 Prohibited	Do not subject the toilet to strong forces or impacts. Otherwise, the toilet may break causing injury or leaks that may damage property.
 Required	Be sure to use the included or specified parts for installation work. Otherwise, the product may not be installed properly. Carry out the installation work according to this installation manual. Otherwise, damage caused by water leaks may occur.

FR

Exécutez correctement l'installation en suivant ces instructions de montage afin de vous assurer que le produit fonctionne convenablement. Une fois l'installation terminée, donnez des instructions précises au client.

Mises en garde et avertissements (veuillez toujours respecter ces avertissements.)

Avant l'installation, lisez attentivement les "Mises en garde et avertissements" et montez convenablement l'appareil. Ces instructions de montage contiennent diverses indications pour une installation sûre du produit et pour éviter toute blessure et tout dommage. Ce produit doit être installé par un professionnel. Les indications et leurs significations sont expliquées ci-après.

Exemple de symbole	Signification du symbole
 MISE EN GARDE	Ce symbole indique que toute utilisation incorrecte peut entraîner des blessures ou des dommages matériels.

Les articles devant être observés sont classés par type et sont expliqués au moyen des pictogrammes suivants.

	Le symbole  indique quelque chose d'interdit.		Le symbole  indique que quelque chose doit être fait.
--	---	---	--

 MISE EN GARDE	
 Interdit	Ne soumettez pas le WC à des forces ou à des chocs. Sinon, le WC pourrait être endommagé et entraîner ainsi des blessures ou des dommages matériels dus à des fuites.
 Obligatoire	Veillez à bien utiliser les pièces spécifiées ou fournies pour les travaux d'installation. Sinon, le produit peut ne pas être correctement installé. Effectuez les travaux d'installation conformément à ces instructions de montage. Sinon, des fuites d'eau peuvent survenir.

DE

Führen Sie die Installationsarbeiten entsprechend dieser Anleitung durch, um sicherzustellen, dass das Produkt richtig funktioniert. Geben Sie dem Kunden nach der Installation genaue Anweisungen zur Benutzung.

Vorsichtsmaßnahmen und Warnungen (Beachten Sie diese Warnungen immer.)

Bitte lesen Sie diese "Vorsichtsmaßnahmen und Warnungen" vor der Installation aufmerksam durch und bringen Sie das Produkt entsprechend an. Diese Anleitung enthält zahlreiche Hinweise zur sicheren Installation des Produkts sowie Anmerkungen, wie Sie Verletzungen und Schäden vermeiden können. Das Produkt sollte durch einen professionellen Installateur eingebaut werden. Die Hinweise und ihre Bedeutung sind im Folgenden erklärt.

Symbol-Beispiel	Bedeutung des Symbols
 VORSICHT	Dies weist darauf hin, dass eine falsche Bedienung zu körperlichen Verletzungen oder Sachschäden führen kann.

Zu beachtende Punkte sind nach Typ klassifiziert und anhand der folgenden Piktogramme erläutert.

	Mit  werden verbotene Arbeitsinhalte gekennzeichnet.		Mit  werden unbedingt auszuführende Arbeitsinhalte gekennzeichnet.
---	---	---	---

 VORSICHT	
 Verboten	Setzen Sie das WC keinen starken Kräfteinwirkungen oder Stößen aus. Das WC könnte beschädigt werden und so zu Verletzungen oder zu Sachschäden durch Wasserlecks führen.
 Zwingend erforderlich	Verwenden Sie für die Installationsarbeiten unbedingt die mitgelieferten bzw. vorgeschriebenen Teile. Anderenfalls besteht die Möglichkeit, dass eine ordnungsgemäße Installation nicht möglich ist. Bitte führen Sie die Installationsarbeiten der Anleitung folgend aus. Anderenfalls könnte es zu Wasserlecks kommen.

IT

Eseguire il lavoro di installazione correttamente seguendo questa Guida per l'installazione, in modo che il prodotto possa funzionare bene. Dopo l'installazione, spiegare completamente al vostro cliente come utilizzarlo.



Precauzioni e avvertenze (Osservare sempre queste avvertenze.)

Prima dell'installazione, si prega di leggere attentamente queste "Precauzioni e avvertenze" per un montaggio corretto dell'apparecchio. Questo manuale utilizza varie indicazioni per l'installazione sicura del prodotto e per la prevenzione di lesioni fisiche ai consumatori o altre persone, ed anche per danni materiali. Questo prodotto deve essere installato da un installatore professionale. Le indicazioni e i loro significati sono riportati come segue.

Indicazione	Significato del simbolo
 Attenzione	Questo indica che un'operazione errata può avere come conseguenza lesioni o danni fisici.

Le tipologie di voci da osservare sono classificate e spiegate da pittogrammi come viene riportato di seguito.

	 Il simbolo alla sinistra indica qualcosa che è proibito.		 Il simbolo alla sinistra indica qualcosa che deve essere eseguito.
---	--	---	--

 Attenzione	
 Proibito	Non esercitare una forza eccessiva o urto al Washlet. In caso contrario, il Washlet potrebbe essere rotto provocando lesioni fisiche o perdita di acqua che causa danni materiali.
 Richiesto	Assicurarsi di utilizzare le parti incluse o specificate per il lavoro di installazione. In caso contrario, il prodotto può non essere installato correttamente. Eseguire il lavoro di installazione in conformità a questo manuale per l'installazione. In caso contrario, potrebbero verificarsi danni causati da perdite d'acqua.

제품이 제대로 기능할 수 있도록 이 시공 설명서의 내용에 따라 올바르게 설치하십시오.
설치 후에는 고객에게 사용 방법을 충분히 설명하십시오.

안전에 관한 주의사항 (안전을 위해 반드시 준수하십시오)

시공에 앞서 이 '안전에 관한 주의사항'을 잘 읽은 후, 올바르게 설치하십시오.
이 설명서에는 제품을 안전하고 올바르게 설치하여 고객 및 다른 사람들에 대한
위해와 재산상의 손해를 미리 방지하기 위한 여러 가지 표시가 있습니다.
그 표시와 의미는 다음과 같습니다.

표시	의미
	이 표시 부분의 내용을 무시하고 잘못 취급할 경우, 인체에 상해를 입거나 물질적인 손해가 발생할 가능성이 예상되는 사항을 나타냅니다.

지켜야 할 사항을 다음 그림 표시로 구분하여 설명하겠습니다.

	○ 는 해서는 안 되는 '금지' 사항입니다. 왼쪽 그림은 '금지'를 나타냅니다.		! 는 반드시 실시해야 하는 '강제' 사항입니다. 왼쪽 그림은 '반드시 실시'를 나타냅니다.
--	---	--	--

주의	
	변기에 강한 힘이나 충격을 가하지 마십시오. 변기가 파손되어 다치거나, 누수의 발생으로 가재 등이 젖어 재산상 손해 발생 위험이 있습니다.
	설치 공사에 사용하는 부품은 반드시 부속 부품 및 지정 부품을 사용하십시오. 정상적으로 설치되지 않을 수 있습니다.
	설치 공사는 이 설명서에 따라 확실하게 시공하십시오. 고장이나 누수가 발생할 수 있습니다.

為充分發揮商品機能，請依照本施工說明書內容正確安裝。
安裝後，請向顧客詳細說明使用方法。

安全注意事項 (為安全起見請務必遵守)

施工前請詳閱「安全注意事項」，再正確施工。為使您安全正確地安裝本商品，並防範對您及其他使用者造成危害或財產損失，本說明書中列出各種不同標示。各標示及其含意如下所示。

標示	意義
	若忽視本標示欄的內容而操作錯誤，可能會導致人員受傷或財物損失。

以下列圖示區分並說明應遵守的內容種類。

	○ 代表絕對「禁止」的行為。 左圖表示「禁止」。		! 為務必執行的「強制」內容。 左圖表示「務必執行」。
--	-----------------------------	--	--------------------------------

注意	
	請勿對馬桶施加重力或撞擊 可能導致馬桶破損，造成人員受傷或漏水弄溼設備等財物損失。
	安裝時請務必使用附屬零件及指定零件 可能無法正常安裝。
	安裝時請遵照本說明書確實執行作業 否則將導致故障與漏水。

Included Parts / Mitgelieferte Teile / Pièces fournies / Parti incluse / 동봉 부품 / 包裝內零件

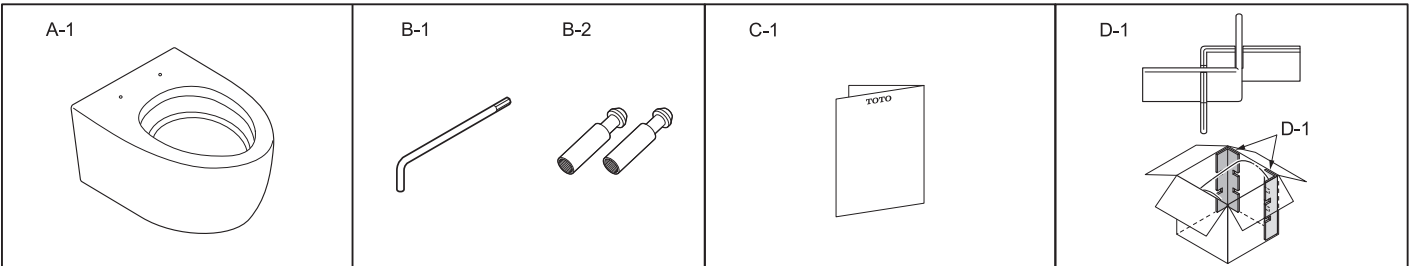

Parts name / Teilebezeichnung / Désignation des pièces / Descrizione parti / 각부의 설명 / 關於各部位之說明

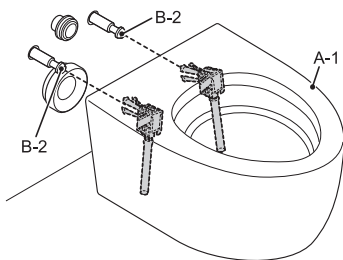

- * The product may be slightly different in shape than the product shown in the figure depending on the model. /
- * Je nach Modell kann die Form des Produkts leicht von der Abbildung abweichen. /
- * La forme du produit peut être légèrement différente que celle illustrée, en fonction du modèle. /
- * A seconda del modello, il prodotto potrebbe avere una forma leggermente differente da quella mostrata nell'illustrazione. /
- ※ 품번에 따라 그림과 실제 제품의 형태가 일부 다를 수 있습니다. /
- ※ 依型號不同，圖示與實際產品的形狀可能有部分差異。

**Before Installing / Vor der Installation / Avant l'installation /
Prima dell'installazione / 설치 전 주의 / 安裝前注意事項**

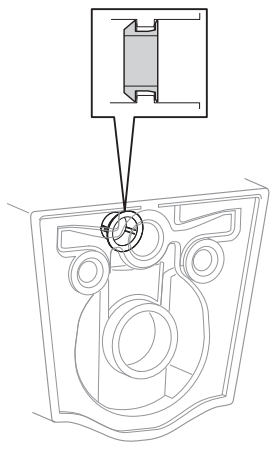
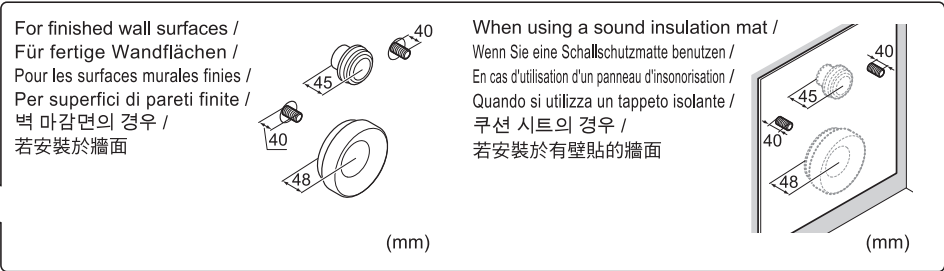
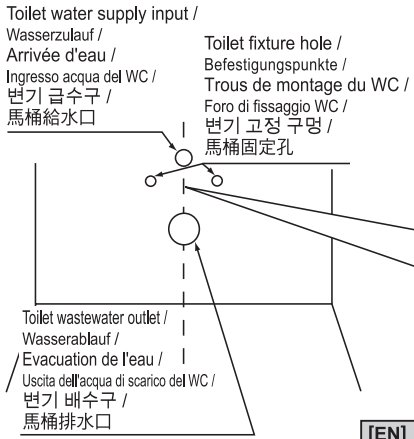

[EN]	CAUTION
Required	Confirm that the part shown in the figure to the left is installed to the toilet bowl. If the toilet bowl is installed without this part, water could spray from the toilet bowl.
[DE]	VORSICHT
Zwingend erforderlich	Überprüfen Sie, ob das in der Abbildung links dargestellte Teil im Toilettenbecken angebracht ist. Wenn das Toilettenbecken ohne dieses Teil montiert wird, könnte Wasser aus dem Toilettenbecken spritzen
[FR]	MISE EN GARDE
Requis	Vérifier que la pièce mentionnée dans la figure de gauche est bien installée avec la cuvette des toilettes. Si la cuvette est installée sans cette pièce, de l'eau pourrait jaillir de la cuvette.
[IT]	ATTENZIONE
Obbligatorio	Verificare che il componente illustrato nella figura a sinistra sia installato sul water. Se si installa il water senza questo componente, l'acqua potrebbe fuoriuscire dal water.
[KO]	주의
반드시 실시	변기에 왼쪽 그림의 부자재가 연결되어 있는지 확인하십시오. 부자재 없이 변기를 설치하면 변기에서 물이 될 수 있습니다.
[TW]	注意
務必執行	請確認馬桶上是否有安裝左圖的零件。 若裝設無此零件的馬桶，可能導致水自馬桶內部噴出。

**For Installers / Für Installateure / Pour les installateurs /
Per gli installatori / 시공업자님께 드리는 부탁 말씀 / 致施工業者**

Use D-1 as support when installing the toilet bowl. / Verwenden Sie D-1 beim Installieren des Toilettenbeckens als Hilfe. /
Utilisez D-1 comme support lorsque vous installez la cuvette. / Utilizzare D-1 come supporto durante l'installazione del water. /
D-1은 변기 설치 시, 보조로서 사용 해 주십시오. / 安裝馬桶時，請使用D-1作為支撐用。

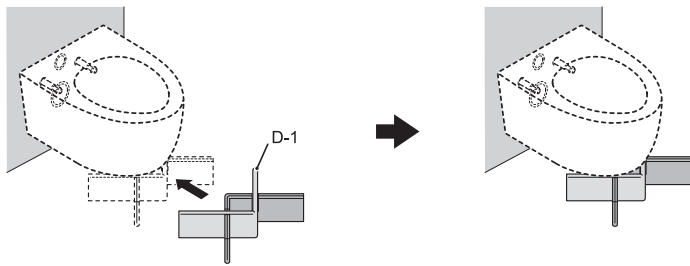

Do not place anything other than the toilet bowl on it. /
Setzen Sie nichts anderes als die Toilettenschüssel darauf. /
Ne placez aucun objet dessus, à part la cuvette des toilettes. /
Non collocarvi sopra oggetti diversi dal water. /
변기 이외의 물건은 올려놓지 마십시오. /
請勿放置馬桶以外的物品

**Installation Procedure / Vorgehensweise für die Installation / Procédures d'installation /
 Procedure di installazione / 설치 방법 / 安裝方法**

**Symbols and their meanings / Symbole und deren Bedeutung / Symboles et significations /
 Simboli e relativo significato / 표시 의미 / 標示與意義**

 : Visual confirmation required. / Visuelle Bestätigung erforderlich. / Une confirmation visuelle est nécessaire. /
 Necessaria conferma visiva. / 반드시 확인해야 하는 작업입니다. / 目視確認

1

For finished wall surfaces / Für fertige Wandflächen /
 Pour les surfaces murales finies / Per superfici di pareti finite /
 벽 마감면의 경우 / 若安裝於牆面

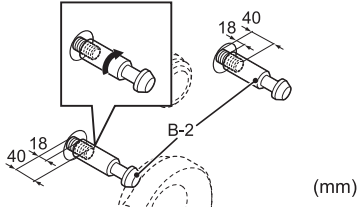

When using a sound insulation mat / Wenn Sie eine Schallschutzmatte benutzen /
 En cas d'utilisation d'un panneau d'insonorisation / Quando si utilizza un tappeto isolante /
 쿠션 시트의 경우 / 若安裝於有壁貼的牆面

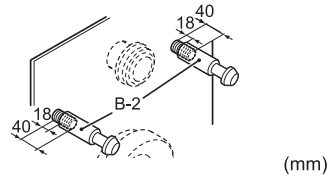

2

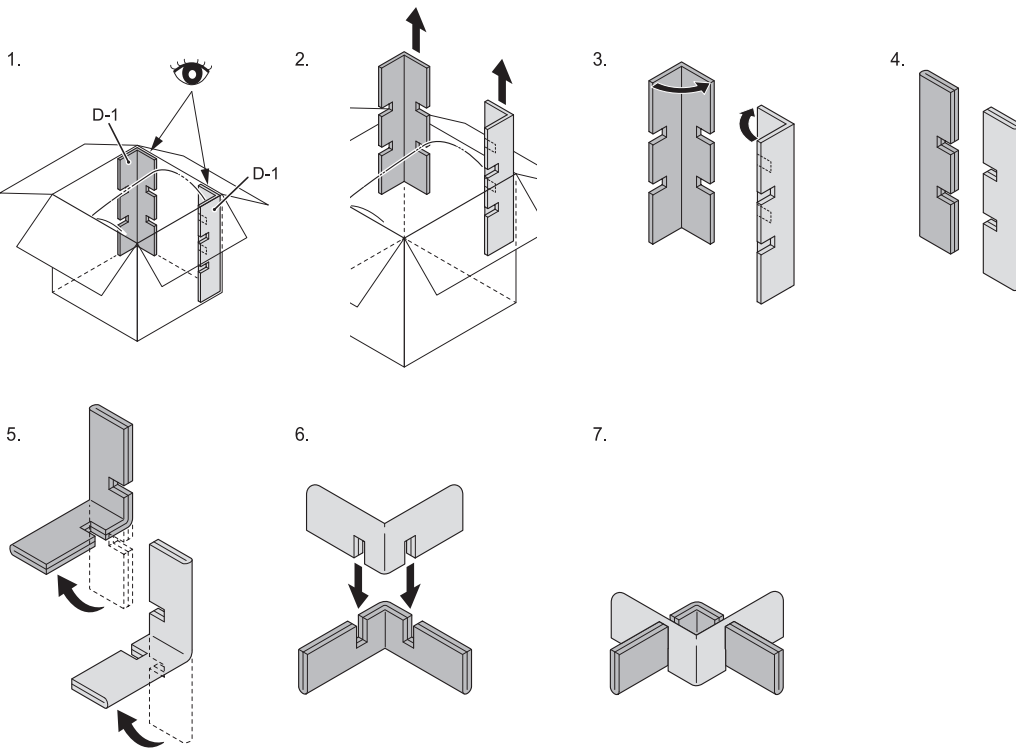

3

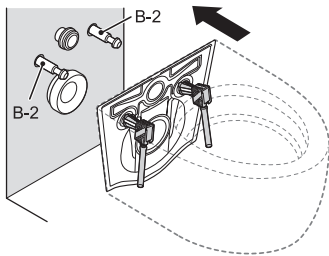

4

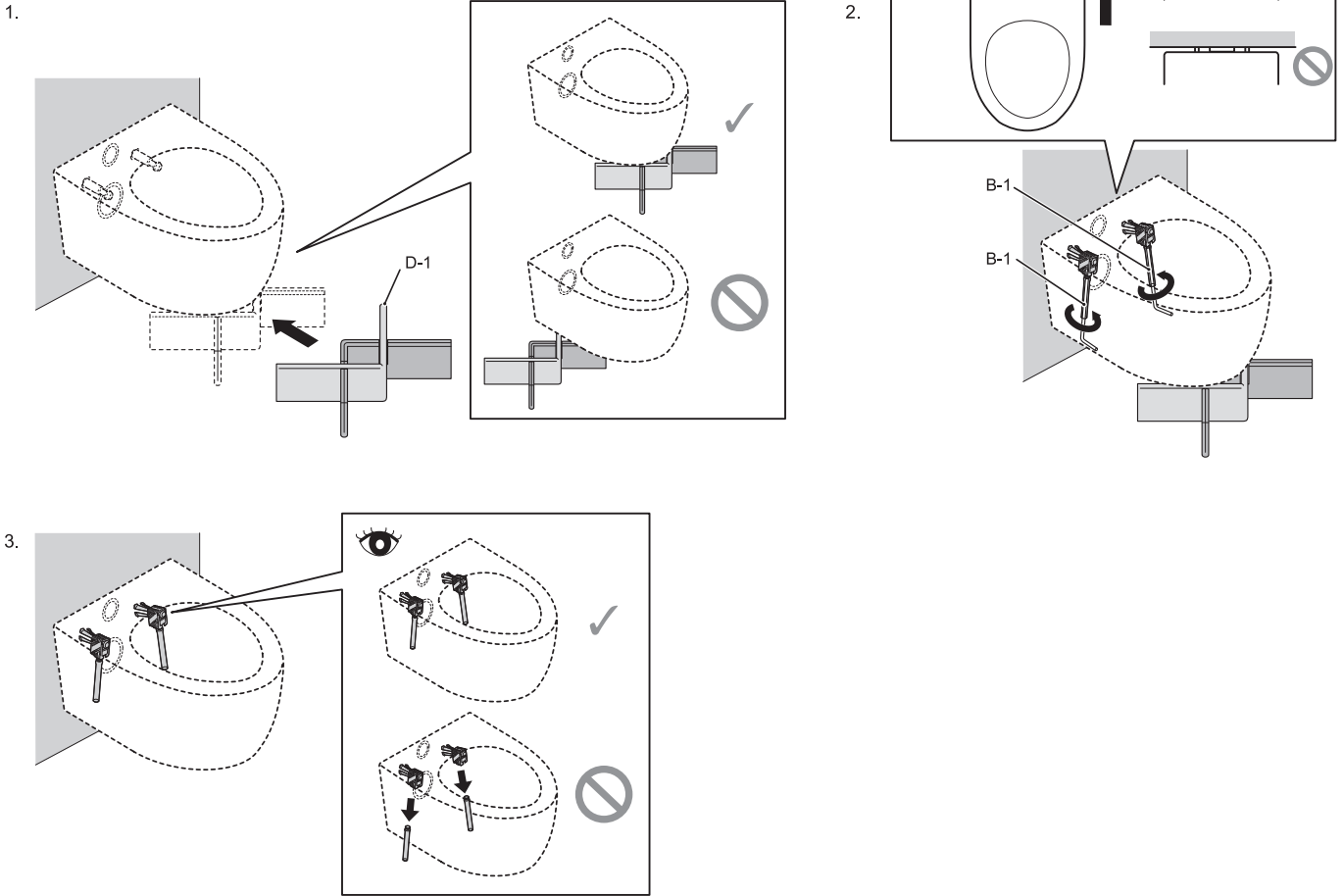

5

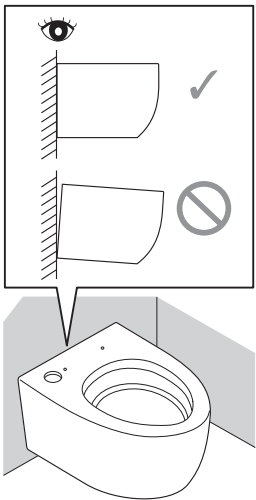

⚠ CAUTION	
❗	Confirm that the toilet is fastened to the wall securely.
Required	Failure to secure the toilet could result in its falling and being damaged.
⚠ VORSICHT	
❗	Stellen Sie sicher, dass das WC sicher an der Wand befestigt ist.
Zwingend erforderlich	Bei unsachgemäßer Befestigung kann das WC herunter fallen und beschädigt werden.
⚠ MISE EN GARDE	
❗	Assurez-vous que le WC est solidement fixé au mur.
Obligatoire	Une mauvaise fixation peut causer la chute du WC et l'endommager.
⚠ ATTENZIONE	
❗	Confermare che il WC sia fissato saldamente alla parete.
Obbligatorio	Se il WC non è assicurato correttamente, potrebbe cadere ed essere danneggiato.
⚠ 주의	
❗	변기가 확실하게 고정되어 있는지 확인하십시오.
반드시 실시	제대로 설치가 되어있지 않은 경우, 변기가 떨어져 파손될 수 있습니다.
⚠ 注意	
❗	確認確實固定住馬桶。
務必執行	若未確實固定，可能導致馬桶掉落而破損。

6

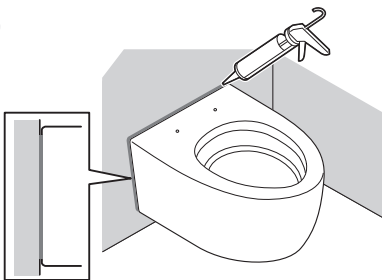

When installing the washlet main unit or standard toilet seat main unit, follow the instructions in the included Installation Guide. /
 Befolgen Sie bei der Installation der Washlet-Haupteinheit oder der Standard-Toilettensitz-Haupteinheit die Anweisungen in der mitgelieferten Installationsanleitung. /
 Lors de l'installation de l'unité principale du bidet ou de l'unité principale de la lunette de toilette standard, respectez les instructions fournies dans le guide d'installation joint. /
 Quando viene installata l'unità principale del washlet o l'unità principale della tavoletta standard, seguire le istruzioni nella guida di installazione inclusa. /
 워쉬렛 본체 또는 일반 변기 시트 설치 시 워쉬렛 본체에 동봉된 시공 설명서 또는 일반 변기 시트에 동봉된 시공 설명서에 따라 설치하십시오. /
 安裝WASHLET本體或普通便座本體時，請依照WASHLET本體包裝內的施工說明書，或是普通便座包裝內的施工說明書進行安裝。

After performing a test run (flush), confirm that there are no foreign substances such as chips from the pipe inside the toilet bowl.

These could cause rust stains and other foreign substances to become attached.

- Confirm that there are no scratches or the like on the porcelain surface. If any metallic objects (such as a wristwatch band or belt buckle) make strong contact with or brush against the porcelain surface, they could leave black or silver line-shaped marks.
- After installation, oil or other substances not visible to the naked eye (such as caulking agent or pipe adhesive) could be left in the toilet bowl. Be sure to use a neutral detergent made for cleaning toilet bowls (without any abrasives) to remove these substances. Otherwise, wash residue could be left on the toilet bowl surface. /

Vergewissern Sie sich nach einer Probspülung, dass sich keine Fremdstoffe wie Späne vom Rohr im Toilettenbecken befinden. Diese können zu Rostflecken und dem Anhaften anderer Fremdstoffe führen.

- Achten Sie darauf, dass sich keine Kratzer oder anderen Schäden auf der Keramikoberfläche befinden. Wenn metallische Gegenstände (wie ein Armband oder eine Gürtelschnalle) in Kontakt mit der Porzellanoberfläche kommen oder darüber kratzen, können schwarze oder silberne Streifen zurückbleiben.
- Nach der Installation können Öl oder andere mit bloßem Auge nicht sichtbare Substanzen (wie Dichtungsmittel oder Rohrklebstoff) im Toilettenbecken verbleiben. Verwenden Sie zur Entfernung dieser Substanzen unbedingt ein neutrales Reinigungsmittel, das zum Reinigen von Toilettenbecken (ohne Schleifmittel) vorgesehen ist. Andernfalls könnten Waschrückstände auf der Oberfläche des Toilettenbeckens zurückbleiben. /

Après avoir effectué un essai (chasse), vérifiez l'absence de substances étrangères, telles que des morceaux du tuyau à l'intérieur de la cuvette des toilettes.

Celles-ci pourraient entraîner des taches de rouille ou la fixation d'autres substances étrangères.

- Vérifiez l'absence de rayures ou autres sur la surface de la porcelaine. Si des objets métalliques (comme un bracelet de montre ou une boucle de ceinture) entrent en contact ou glissent sur la surface de la porcelaine, ils peuvent laisser des marques en forme de lignes noires ou grises.
- Après l'installation, de la graisse ou d'autres substances invisibles à l'œil nu (par exemple un agent de calfeutrage ou un autocollant de tuyau) peuvent rester dans la cuvette des toilettes. Assurez-vous d'utiliser un détergent neutre conçu pour le nettoyage des cuvettes de toilettes (sans abrasifs) pour enlever ces substances. Sinon, des résidus de lavage peuvent rester à la surface de la cuvette des toilettes. /

Una volta eseguito uno scarico di prova (sciacquone), confermare che non ci sono sostanze estranee come schegge nel tubo all'interno del water.

Queste ultime possono contribuire alla formazione di macchie di ruggine e altre sostanze estranee.

- Assicurarsi che la superficie in porcellana non presenti graffi o danni simili. Se un oggetto metallico qualsiasi (come il cinturino un orologio da polso o una fibbia) entra in contatto o si strofina contro la superficie in porcellana, può lasciare righe nere o argentate.
- Una volta eseguita l'installazione, nel water possono rimanere oli o altre sostanze non visibili a occhio nudo (come sigillanti o adesivi per tubi). Assicurarsi di utilizzare un detergente neutro specifico per la pulizia del water (senza abrasivi) per rimuovere queste sostanze. In caso contrario, i residui del lavaggio potrebbero rimanere sulla superficie del water. /

시운전(세정) 후 변기 내에 배관 시의 금속 부스러기 등 이물질이 없는지 확인하십시오.

녹 번짐 등 이물질이 생길 우려가 있습니다.

- 도자기 표면에 흠집 등이 없는지 확인하십시오. 도자기 표면에 금속류(시계 밴드, 벨트 버클 등)를 강하게 접촉하거나 문지르면 검은색이나 은색 줄무늬 모양의 자국이 생길 수 있습니다.
- 시공 후에는 변기 안에 기름 등의 보이지 않는 먼지(코킹제, 배관용 접착제 등)가 부착되는 경우가 있으므로, 연마제가 없는 화장실용 중성세제를 사용하여 반드시 오염물을 제거하십시오. 그대로 방치하면 변기표면 표면에 더러움이 남을 수 있습니다. /

測試運轉 (洗淨) 後, 請確認馬桶洗淨面內沒有裁斷配管後的粉末等異物。

否則可能會導致水鏽等異物附著。

- 請確認陶器表面有無損傷。若金屬類 (手錶錶帶、皮帶帶扣等) 強力接觸或摩擦陶器表面, 有可能會留下黑色或銀色的線狀痕跡。
- 施工後, 在馬桶洗淨面內有可能附著油污等看不見的污垢 (填隙劑、配管用黏著劑等)。請務必使用廁所用中性清潔劑 (無研磨劑) 擦去髒汙。否則可能會導致馬桶洗淨面殘留污垢。

After installation, leave the L-Wrench (B-1) with the customer. /
Den Inbusschlüssel (B-1) nach der Installation dem Kunden aushändigen. /
Après l'installation, laisser la clé en forme de L (B-1) chez le client. /
Dopo l'installazione, lasciare la chiave a forma di L (B-1) presso il cliente. /
시공 후에는 L형 렌치(B-1)를 반드시 고객에게 전달 해 주십시오. /
施工後, 請將L型扳手轉交給顧客